



City of Guyton, Georgia
**DOWNTOWN DEVELOPMENT
AUTHORITY (DDA) MEETING**

December 18, 2024 | 10 A.M.

**Guyton City Hall
310 Central Boulevard
Guyton, GA 31312**

AGENDA

1. **Call to Order**
 2. **Invocation and Pledge of Allegiance**
 3. **Consideration to Approve the Agenda**
 4. **Consideration to Approve the Minutes**
 - ④ 11/20/24 DDA Meeting
 5. **Financial Report**
 6. **Strategic Planning Committee Report**
 7. **Old Business**
 - a) Update on the façade grant program
 8. **New Business**
 - a) Discussion on incorporating recently annexed property parcel number G0100004 into the Downtown District
 - b) Discussion on City Council's decision to have Attorney Perkins research the possibility of the City of Guyton leasing the gymnasium to the DDA
 - c) Discussion on nominating officers for the next cycle
 9. **Consideration to move from the regular meeting into an executive session referencing personnel**
 10. **Consideration to take any action needed arising from executive session**
 11. **Adjournment**
-



**City of Guyton
Downtown Development Authority (DDA) Meeting
November 20, 2024 — 10:00 A.M.**

MINUTES OF MEETING

Call to Order — The City of Guyton Downtown Development Authority held a meeting on November 20, 2024, at the City of Guyton City Hall, 310 Central Blvd in Guyton. The meeting was called to order by Miller Bargeron at approximately 10:00 A.M. Tamela Mydell, Carl Heindel, Keith Lancaster, and Glen Montgomery were also present at this meeting.

Additional Administrative Staff Present — City Clerk Fabian Mann was present.

Guest Present — The guest sign-in sheets are filed in the Office of the City Clerk.

Invocation — The invocation was led by **Mydell**.

Pledge of Allegiance — The Pledge of Allegiance was led by **Bargeron**.

Approval of Agenda — **Mydell** made a motion to approve the agenda. **Heindel** seconded the motion. **Motion passed unanimously**.

Approval of Minutes from October 16, 2024, DDA Meeting — **Heindel** made a motion to approve the minutes. **Lancaster** seconded the motion. **Motion passed unanimously**.

Financial Report

Strategic Planning Committee Report

Old Business

a) **Update on the façade grant program**

b) **Update on the Effingham Arts mural painting proposal**

Mydell made a motion to approve up to \$1,000.00 for mural supplies. **Heindel** seconded the motion. **Motion passed unanimously**.



New Business

- a) **Review of DDA business card sample**
- b) **Discussion on participating in Guyton's Christmas Parade**
- c) **Discussion on posting flyers of events sponsored by downtown businesses to the DDA Facebook page**
- d) **Discussion on adding lights to the Guyton Walking Trail**
- e) **Discussion on Executive Board roles**
- f) **Review façade grant application from Smalls Funeral Home for approval**
Heindel made a motion to approve Smalls Funeral Home's façade grant application.
Montgomery seconded the motion. **Motion passed unanimously.**

Consideration to move from the regular meeting into an executive session referencing personnel — Heindel made a motion to move into an executive session. **Mydell** seconded the motion. **Motion passed unanimously.**

Consideration to take any action needed arising from executive session — No action taken

Adjournment — Mydell made a motion to adjourn. **Heindel** seconded the motion. **Motion passed unanimously.**

Miller Barger, Jr.,
Chairperson

Attest:

Fabian Mann, City Clerk

DDA

12/18/2024

INCOME

FY '25 General Fund	\$	25,000.00
Total Income	\$	25,000.00

EXPENSES

BUDGET SUMMARY

*Façade Grants (10/\$1,000.00)	\$	10,000.00
GDC Registration	\$	2,460.00
GDC Travel & Lodging	\$	974.43
Total Expenses	\$	13,434.43

TOTAL REMAINING

\$ 11,565.57

*Funds yet to be expended

Guyton Downtown Development Authority's Strategic Planning Committee (SPC) Report

The following items were discussed at the DDA SPC meeting on 12/04/2024.

- ❖ Walking Trail Lighting proposal for City Council
 - See attached proposal
- ❖ Sidewalk Planter Proposal for DDA consideration
 - (see attached proposal)
- ❖ Update on the downtown Mural Project
 - All parties have signed the contract for the project. Lindsey Gerow with Effingham Artist has already begun working on the mural. Lindsey has power-washed the wall and is applying several coats of primer paint. Her goal is to complete the mural by New Year - depending on the weather temperature and humidity.

Walking Trail Lighting Project



Proposal

ABSTRACT

This proposal is submitted for Guyton's City Council to consider installing additional lighting along the Walking Trail on Central Ave.





Introduction

The Walking Trail that runs through the center of the City of Guyton on Central Ave is a wonderful outdoor space for community enjoyment. Whether for leisurely walks or scheduled events, more individuals are taking advantage of one of Guyton's greatest assets. However, it becomes a little difficult to safely enjoy the southern charm of the Walking Trail in the evening hours due to the Trail's insufficient lighting. With that in mind, it is of the utmost importance that our citizens and the community at large feel a sense of safety enjoying the Trail – especially during the evening hours.

Project Rationale

As a result of the Walking Trail's insufficient lighting, the Downtown Development Authority (DDA) of Guyton is proposing for consideration of Guyton's City Council the installation of additional lights along the Walking Trail. To facilitate this consideration, Dr. Miller Barger, Jr., the DDA's Chairman, contacted Brian Keith Rose, GA Power's Lighting Executive assigned to the Guyton area, to determine the available options for fulfilling this lighting project. Mr. Rose presented the following two (2) options under GA Power's Lease Program.

Option #1:

Option #1 consists of paying an upfront buy-down fee of \$3,264.00 per installed light. This option includes the light pole, installation, energy, fuel, and ongoing maintenance. The monthly fee per light for this option is \$23.87.

Option #2:

Option #2 consists of paying no upfront fee per installed light. This option includes the light pole, installation, energy, fuel, and ongoing maintenance. The monthly fee per light for this option is \$64.84.

Optional Equipment:

There is also a need for additional electrical outlets around the Walking Trail. GA Power can install electrical outlets on selected light poles for greater access to electricity along the Trail for various events. The cost to install each electrical outlet is approximately \$750.00. The installation cost cannot be added to the monthly bill.

Benefits of Georgia Power's Lease Program

- No Up-front capital investment option.
- Guaranteed maintenance included. GA Power will repair a broken light within three to five days after it is reported.
- Flat monthly rate. With the flat payment, there are no unpredictable expenses associated with the maintenance and upkeep of the system.



- No ownership risk. Georgia Power will retain ownership of the lighting system and provide all maintenance parts and labor. This includes repairs or replacement.

*** See the *Streetworks* attachment for information on the proposed light pole.

Project Proposal

Based on the current level of lighting along the Walking Trail, the DDA proposes that City Council consider adding 15 – 20 light poles to provide optimal lighting for the Walking Trail. In addition, the DDA proposes that 3 – 4 electrical outlets are added to select light poles. The additional lights should be installed in areas in need of the most lighting, including the areas boarding Gracen Road. The electrical outlets will be placed where they are deemed most useful.

With the City of Guyton’s budgetary capacity not known, a recommended GA Power Leasing Program option is not included in this proposal. It is suggested that City Council review the cost options and select an option that exhibits the best fiduciary responsibility.

Conclusion

The Downtown Development Authority presents this proposal to improve the lure of the downtown district for individuals and businesses alike. With the citizens of Guyton and the community at large in mind, this investment for safety is proposed to City Council for consideration. Feel free to modify the proposed number of lights and electrical outlets as needed to accommodate any budget parameters.

Contact For Questions/Additional Information

Dr. Miller Bargeron, Jr., *DDA Chairman*

Miller.Bargeron@cityofguyton.com



Or

Brian Keith Rose, *Lighting Executive, GA Power*

bkrose@southernco.com



STREETWORKS™

DESCRIPTION

The Traditionaire LED outdoor luminaire displays the old-fashioned charm of traditional area lighting, enhancing any setting with distinctive styling. As a decorative luminaire, the Traditionaire LED tastefully complements the architectural and environmental design of parks and roadways. The high-lumen downlight configuration uses Cooper Lighting's patented LightBAR™ technology to deliver uniform and efficient illumination to pedestrian and roadway applications.

Catalog #	UTLDC03LEDDUT2A	Type	
Project	SELMA STREET HOUSING	Date	
Comments			
Prepared by	BKROSE		1/25/2015

SPECIFICATION FEATURES

Construction

Hinged (stainless steel hinge pins) die-cast aluminum housing and cover with cupola. 3G vibration tested to ensure strength of construction and longevity in application.

Optics

Choice of several patented, high-efficiency AccuLED Optics™ elements manufactured from injection-molded acrylic. Optics are precisely designed to shape the distribution maximizing efficiency and application spacing. The AccuLED Optics system create consistent distributions with the scalability to meet customized application requirements. Offered standard in 4000K (+/- 275K) CCT and nominal 70 CRI.

Electrical

LED drivers are potted and equipped with heat sinks for optimal performance and prolonged life. Standard drivers feature electronic universal voltage (120V-277V/50-60Hz), greater than 0.90 power factor, and operating temperature range from -30°C to +40°C. Includes surge protection for transient line surges up to 10kV. Standard three-position tunnel-type terminal block. System is rated for 90% lumen maintenance at 60,000 hours (compliant with IESNA TM-21).

Mounting

Self-aligning pole-top fitter for 3" O.D. pole tops or vertical tenons. Square headed 1-1/4" polymer coated mounting bolts with a lock nut.

Finish

Cast components finished in a Super durable black TGIC polyester powder coat paint, 2.5 mil nominal thickness for superior protection against fade and wear. Optional colors include: bronze, grey and white. RAL and custom color matches available.

Warranty

Five-year warranty.



UTLD TRADITIONAIRE LED DOWNLIGHT

Solid State LED

DECORATIVE POST TOP LUMINAIRE

DIMENSIONS

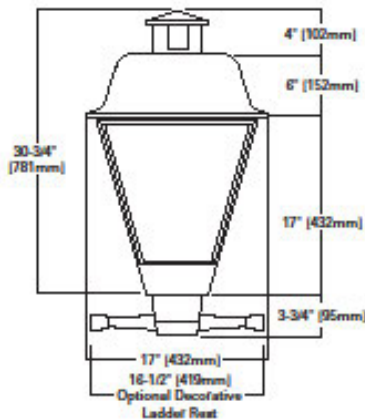

OPTIONAL BIRD CONE

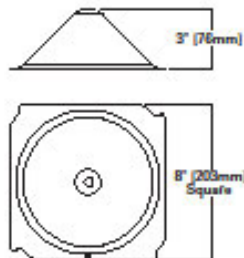

CERTIFICATION DATA
-30°C to 40°C Ambient Temperature Range
LM79/LM80 Compliant

EPA
Effective Projected Area:
2.3 Sq. Ft.

SHIPPING DATA
Approximate Net Weight:
37 lbs. (17 kgs.)



ADW120809
2014-08-25 11:00:05



UTLD TRADITIONAIRE LED DOWNLIGHT

POWER AND LUMENS (STANDARD CONFIGURATION - NO LENSES OR BIRD CONE)

LED LightBARs	B01	B02	B03	C01	C02	C03	
Number of LEDs	21 LEDs	21 LEDs	21 LEDs	7 LEDs	7 LEDs	7 LEDs	
Power (Wattage)	27	51	73	27	58	79	
Current @ 120V (A)	0.23	0.43	0.61	0.23	0.47	0.66	
Current @ 277V (A)	0.10	0.18	0.26	0.10	0.20	0.29	
Optics							
T2A	Lumens	1,990	4,036	5,745	1,588	3,167	4,508
	BUG Rating	1-0-1	1-0-1	2-0-2	1-0-1	1-0-1	1-0-1
T3A	Lumens	2,038	4,116	5,858	1,599	3,230	4,597
	BUG Rating	1-0-1	2-0-2	2-0-2	1-0-1	1-0-1	2-0-2
SL2	Lumens	1,959	3,955	5,629	1,537	3,104	4,417
	BUG Rating	1-0-1	1-0-1	1-0-2	1-0-1	1-0-1	1-0-1
SL3	Lumens	2,022	4,083	5,811	1,587	3,204	4,580
	BUG Rating	1-0-1	1-0-1	1-0-2	0-0-1	1-0-1	1-0-2
SMQ	Lumens	2,149	4,339	6,175	1,686	3,405	4,846
	BUG Rating	1-0-1	2-0-1	3-0-1	1-0-1	2-0-1	2-0-1
SWQ	Lumens	2,115	4,272	6,080	1,680	3,352	4,771
	BUG Rating	2-0-1	3-0-1	3-0-1	1-0-1	2-0-1	3-0-1

ORDERING INFORMATION

Sample Number: UTLD03LEDEUT3S

Product Family	Number of LightBARs 1,2	Source Type	Driver	Voltage	Distribution
UTLD-Traditionaire™ LED Downlight	B01-(1) 21 LED LightBAR B02-(2) 21 LED LightBARs B03-(3) 21 LED LightBARs C01-(1) 7 LED LightBAR C02-(2) 7 LED LightBARs C03-(3) 7 LED LightBARs	LED-Solid State Light Emitting Diodes	E-Non-Dimming D-Dimming	U-Universal (120-277V) s-480V s-347V	T2A-Type II Area T3A-Type III Area SL2-Type II w/Spill Control SL3-Type III w/Spill Control SMQ-Type V Square Medium SWQ-Type V Square Wide
Options (Add as Suffix)					Accessories (Order Separately)
4-Internal NEMA Photocontrol Receptacle W-20' #10 Leads S-Snap Latches for Tool-less Light Replacement U-UL/CSA Listed J-Factory Installed Ladder Rest 7060-70 CRI/3000K CCT 3 8090-80 CRI/3000K CCT 3 2L-Two Circuits 4 A-Acrylic Lens Panels 5 LCF-LightBAR Cover Plate Matches Housing Finish BC-Bird Cone 6 AP-Gray BZ-Bronze WH-White					TA1BK-Decorative Ladder Rest for Field Installation OA1222-10kV Surge Replacement Module

- Notes:**
- 21 LED LightBAR driven at 250mA, 7 LED LightBAR driven at 1A.
 - Standard 800K CCT and nominal 70 CRI.
 - Consult factory for lead times and lumen multiplier.
 - Low-level output varies by bar count. Consult factory. Requires two or more LightBARs.
 - Acrylic lens panels and bird cone can not be ordered together.



Salon
1000 Salon Boulevard
Cleveland, OH 44122
United States
Salon.com

Salon's Cooper Lighting Division
1121 Highway 91 South
Peachtree City, GA 30089
P: 770-486-6900
www.cooperlighting.com

Specifications and dimensions subject to change without notice.

ADW120809
2014-08-25 11:00:05



GUYTON DOWNTOWN DEVELOPMENT AUTHORITY

PLANTER PROPOSAL

PROJECT DESCRIPTION

ADD 16-18 PLANTERS TO THE MAIN STRIP IN DOWNTOWN GUYTON TO ASSIST IN BEAUTIFYING THE CITY. PLANTERS WILL START AT CITY HALL AND END AT BOLTS AND BULLETS.

PROJECT OBJECTIVES

TO ASSIST BUSINESS OWNERS AND THE CITY OF GUYTON IN ADDING VISUAL APPEAL AND A FRESH LOOK TO DOWNTOWN GUYTON.

PRODUCTS NEEDED

- 2 PLANTERS AT EVERY BUSINESS ENTRY WAY (SOUTHERN KAFE COULD PLACE PLANTERS ON EITHER SIDE OF ENTRANCE RAMP)
 - [HTTPS://WWW.EPLANTERS.COM/COSAPOTS-MONDO-HIGH.HTML](https://www.eplanters.com/cosapots-mondo-high.html)
- PLANTING SOIL/ANNUAL FLOWERS

COST OF PROJECT

- 18 PLANTERS X \$517= \$9,306 - CONTRACTOR DISCOUNT + + \$289 SHIPPING = \$7,402.98
- PLANTING SOIL= \$350(1 BAG PER PLANTER)
- ANNUAL FLOWERS = 1,764(10 FLATS OF ANNUALS, 18 2-QUART KALE + 18 DUSTY MILLERS)



PLANTER 1.7" W X 30.9" H



DUSTY MILLER



PERENNIAL



KALE



CITY OF GUYTON

STATE OF GEORGIA

ORDINANCE NO. 2024-10

AN ORDINANCE TO ANNEX CERTAIN PROPERTY INTO THE CITY OF GUYTON, GEORGIA PURSUANT TO CHAPTER 36 OF TITLE 36 OF THE OFFICIAL CODE OF GEORGIA ANNOTATED, AND TO AMEND THE ZONING ORDINANCE AND OFFICIAL ZONING MAP OF THE CITY OF GUYTON, GEORGIA, AS AMENDED, TO REZONE CERTAIN PROPERTY CURRENTLY KNOWN AS EFFINGHAM COUNTY PARCEL NO. 02940042 FROM EFFINGHAM COUNTY ZONING CLASSIFICATION AR-1 TO CITY OF GUYTON ZONING CLASSIFICATION C-1; TO REPEAL ALL ORDINANCES IN CONFLICT HEREWITH; TO PROVIDE AN EFFECTIVE DATE; AND FOR OTHER PURPOSES.

IT IS HEREBY ORDAINED BY THE GOVERNING AUTHORITY OF THE CITY OF GUYTON, GEORGIA in a regular meeting assembled and pursuant to lawful authority thereof, as follows:

- SECTION 1.** That area contiguous to the City of Guyton, currently known as Effingham County Parcel No. 02940042 is hereby annexed into the City of Guyton and is made a part of said city.
- SECTION 2.** That the zoning ordinance and Official Zoning Map of the City of Guyton, Georgia, as amended, be amended so that Parcel No. 02940042 (currently zoned Effingham County zoning classification AR-1), shall be rezoned to City of Guyton zoning classification C-1.
- SECTION 3.** That the City Zoning Official and/or the City Clerk of Guyton is instructed to send within 30 days of the effective date of this ordinance an annexation report required under O.C.G.A. § 36-36-3 to: (1) the governing authority of Effingham County; (2) the Georgia Department of Community Affairs; and (3) the United States Census Bureau. The annexation report shall contain all information required under O.C.G.A. § 36-36-3.
- SECTION 4.** This ordinance shall become effective upon adoption.
- SECTION 5.** All ordinances and parts of ordinances in conflict with this ordinance are hereby repealed.

SO ORDAINED, this 10th day of December, 2024.

CITY OF GUYTON

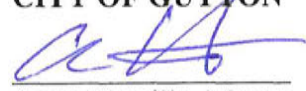

Andy Harville, Mayor

ATTEST:



Fabian Mann, City Clerk



**BY-LAWS
of the
CITY OF GUYTON DOWNTOWN DEVELOPMENT AUTHORITY
for the City of Guyton, Georgia**

ARTICLE 1 – NAME AND PURPOSE

Section 1-1. Name

The Mayor and City Council of the City of Guyton activated the Guyton Downtown Development Authority (“DDA”) by Resolution # 2023-07 on May 9, 2023. Directors of this Authority (“Directors”) shall henceforth exist under this authority with all of its rights, responsibilities and limitations in accordance with the DDA Law, O.C.G.A. 36-42-1, et seq. The name of the Authority shall be the Guyton Downtown Development Authority, otherwise referred to in these by-laws as “DDA”. The DDA will serve the geographical area within the municipal boundaries of the City of Guyton as indicated on the map attached hereto as Exhibit A.

Section 1-2. Purpose

The purpose of the DDA is to provide technical assistance and financial opportunities with incentives, as available, that encourage quality economic growth and development while preserving Guyton’s unique architectural and community heritage. This purpose will be carried out with DDA Directors’ involvement by facilitating public and private efforts to revitalize, redevelop, and enhance that which improves the quality of life for those that live, work, and visit Guyton. This purpose will also be realized by working collaboratively with partners towards achieving goals identified within the City of Guyton’s Comprehensive Plan to maintain the City’s sense of place.

ARTICLE 2 – VISION/MISSION AND DEVELOPMENT OF WORK PLANS

Section 2-1. Vision

Vision Statement: The Vision of the DDA is to improve the quality of life for those that live, work, and visit Guyton and enhance the cultural experience while preserving the community's cultural heritage.

This Vision will be achieved through the Directors’ commitment to historic preservation-based economic development that balances design, business assistance, promotion, and organization with established committees and partners that represent each point.

ARTICLE 3 – BOARD OF DIRECTORS

Section 3-1. Management Powers, Number, Qualification and Term.

The property, affairs and business of the DDA shall be managed by its Directors, consisting of seven persons with applicable qualifications and appointed as provided by law (O.C.G.A. 36-42-1). Each Director shall be appointed by the elected officials of the City of Guyton and hold office for a term of four (4) years following expiration of the terms filled upon the City’s activation of the DDA on May 9, 2023.

If necessary, a Director whose term of office has expired shall continue to hold office until a qualified successor is appointed. If a vacancy is created by the death, resignation or removal of a Director, a successor shall be appointed in the same manner as the original appointment, but for the unexpired term only.

Section 3-2. Personnel

Any staff of the DDA, whether appointed by the City or directly employed by the DDA (“Employee”) may be a non-voting member of the DDA and shall be present at all meetings held

by the Directors. The Employee shall manage and coordinate the DDA's policies and projects and perform other duties as the City Manager and Directors may require.

The Employee, with advice of the DDA Chair and/or Executive Committee, shall prepare the DDA's agendas for all regular and special meetings and send them to the Directors at least twenty-four (24) hours prior to the meeting. Any Director may request that an item be placed on the agenda, but all such requests shall be submitted through the Chair and/or Executive Committee. However, the Employee shall utilize discretion in the quantity of agenda items in order to maintain the timeframe of the meeting.

In the absence of said Employee, the City of Guyton shall seek to fill this position with input from the DDA's Executive Board.

Section 3-3. Powers and Responsibilities.

DDA Directors shall have such power and authority as is conferred upon them in accordance with the terms and provisions of the Downtown Development Authority Law as it now exists and as it might hereafter be amended or modified.

To achieve the goals of the DDA, any member of the Board can participate in any of the committees created by the Board, and will participate in any Board development workshops, required trainings, and other activities that will benefit the individual's dedication to the DDA. All new Directors shall participate in an orientation program familiarizing them with the goals and objectives of the DDA and with their responsibilities.

Directors shall show their commitment to the DDA through attendance at regularly scheduled meetings, special meetings, and meetings of committees on which they serve. If a Director has three (3) consecutive absences or four (4) or more unexcused absences in the course of one year, at any of the above mentioned meetings, the Chairperson may, with majority approval from the Board, submit a recommendation to the City Council for said Director to be removed from the Board. Extenuating circumstances, such as, but not limited to, personal or employment circumstances, will be considered.

Section 3-4. Regular Meetings.

Regular meetings of the Authority shall be held on the Third Wednesday of each month at 10:00 A.M. Meetings may be called by the Chairperson or at the request of at least fifty percent of the Directors via email or fax to each Director at least 48 hours prior to such meeting. All meetings shall comply with the Georgia Open Meetings Act (O.C.G.A. Section 50-14-1).

Section 3-5. Special Meetings.

Special meetings may be held upon request of the Chairperson, Vice-Chairperson in the absence of the Chairperson, or the Employee with a written request of four (4) or more Board Members, by giving twenty-four (24) hour notice of the meeting, stating the purpose of the meeting and by posting a public notice of the meeting, as per the Georgia Open Meetings Act (O.C.G.A. Section 50-14-1). Notice of a special meeting may be either provided in person, via telephone, fax, or email.

Section 3-6. Quorum.

A quorum shall consist of at least four Directors attending a meeting in person. If the in-person quorum is met, a member may participate by teleconference if necessary due to reasons of health or absence from the jurisdiction so long as the other requirements of the Open Meetings Act are met. Directors attending meetings via teleconference will be allowed to vote, but their presence may not count towards a quorum. Decisions are made by majority vote of those at a meeting in which a quorum is present. If four or more Directors are absent from a meeting, a majority of the Directors present may adjourn the meeting without further notice, until a

quorum has been obtained. No member shall participate by teleconference pursuant to this subsection more than twice in one calendar year.

Section 3-7 Disclosure of Interest

A Director who has a conflict of interest in any matter before the Board shall disclose that interest and recuse themselves prior to the Board taking any action.

Section 3-8. Parliamentary Procedures.

The most current ***Roberts Rules of Order***, or a reasonable interpretation thereof, shall govern the parliamentary procedures of the Authority when not in conflict with these by-laws. The order of business may be altered or suspended at any meeting by a majority vote of the Directors present.

Section 3-9. Nominations of Directors.

Prior to the expiration of a Director's term, the Executive Committee shall seek and make recommendations for qualified individuals, in accordance with the activation resolution adopted May 9, 2023, to be appointed by the Mayor and City Council of the City of Guyton. Directors may, from time to time, make suggestions to the elected officials for new Director and vacant Director positions in order to assist in meeting the needs and goals of the DDA.

ARTICLE 4 – AUTHORITY AND DUTIES OF DIRECTORS AND OFFICERS

Section 4-1. Number and Term.

Directors shall elect from one of their members a Chairperson, a Vice-Chairperson, a Treasurer, and a Secretary to be Officers of the Authority. The Officers shall serve one calendar year terms (January through December), and are eligible to be re-elected to the same position.

Section 4-2: Duties of Officers

The Chairperson shall preside at meetings of the Board and shall perform such other duties as may be, from time to time, assigned by the Board. The Chairperson shall be a voting member of the Board.

The Vice-Chairperson shall perform the duties of the Chairperson in the Chairperson's absence and such other duties as, from time to time, are assigned by the Board.

The Treasurer shall review and present to the Board for approval all DDA revenue and expense reports prepared by Employee and Finance Director of the City. In the absence of Employee or Finance Director of the City, the Treasurer will be responsible for tracking all funds, expenses and revenues.

The Secretary shall record, review and present to the Board for approval all DDA meeting minutes, committee minutes and correspondence.

The Officers, with Employee as an ex-officio member, shall serve as the Executive Committee and shall oversee and advise the direction and actions necessary for the daily management of the DDA.

Section 4-3. Election and Removal.

A meeting shall be held after the DDA is activated and within the first three months of each year thereafter for the purpose of electing new Officers. Notice of the time and place of such meeting shall be given.

All officers shall be elected by and serve at the discretion of the Board. Any officer may be removed from office, either with or without cause, at any time, by the affirmative vote of a majority of the Directors then in office.

Section 4-4. Powers.

The powers and duties of the Officers shall be as provided herein and as provided from time to time by resolution or other directive of the Directors. In the absence of such provisions, respective Officers shall have the powers and shall discharge the duties customarily and usually held and performed by like officers of authorities similar in organization and purposes to this DDA.

ARTICLE 5 – COMMITTEES

Section 5-1. Establishing Committees

The Board of Directors may, by majority vote, establish committees as needed. The committees shall be composed of any Board members the Board deems appropriate, as well as any non-Board members deemed appropriate (“Board-appointed liaison(s)”). The Board may make provisions for appointment of the liaison(s) of such committees; establish such procedures to govern their activities, and delegate thereto such authority as may be necessary or desirable for the efficient management of the property, affairs, business, and activities of the DDA. Sub-committees may be established by majority vote of the Directors to address specific issues and items within the DDA’s purview.

Section 5-2. Responsibilities of Committees

The committee members shall effectively and efficiently carry out the goals of the DDA and make recommendations to the Board of Directors for final decisions reflective of the purpose of the DDA.

The Board-appointed liaison, committee chairperson, or her/his designee shall be responsible to determine and schedule Committee meeting times, dates, and locations, send committee meeting reminders, prepare materials, and coordinate committee activity in conjunction with the DDA as dictated by a majority of Directors. The Board-appointed liaison, committee chairperson, or her/his designee will notify Employee and Directors of its meetings and will keep written reports of its proceedings and forward those reports to Employee and Directors. The committees do not have authority to take action, act on proposed plans, or enter into contracts or purchase agreements without obtaining approval of the Board. The designation and appointment of committees and the delegation thereto of authority shall not operate to relieve the Board of Directors, or any individual Director, of any responsibility imposed upon them by law.

Section 5-3. Advisory Committee

The Board, by resolution, may designate and appoint one (1) or more stakeholder groups to advise the Board on the direction of the DDA. The members of such advisory groups may be selected by majority vote of Directors.

ARTICLE 6: FINANCIAL ADMINISTRATION

Section 6-1. Fiscal Year.

The fiscal year of the DDA shall run from July 1- June 31.

Section 6-2. Budget

Directors shall prioritize goals for the DDA and approve a proposed budget outlining necessary details, ideally two months prior to the new fiscal year. The approved budget may be reviewed and revised periodically as deemed necessary by the Directors.

Section 6-3. Revenue and Expenditures

All revenues and expenditures for the DDA shall be reviewed at each regular scheduled Board of Directors meeting. Requests for funding and payments shall be submitted to the Employee. The employee shall then review the request and prepare it for Treasurer, or other Officer, approval.

Once approved by the Treasurer, the payment shall be processed and presented to the Chairperson (or other Officer) to be signed. The Officer approving the payment shall not be the same Officer to sign the check.

Section 6-4. Compensation

Directors shall receive no compensation. Should a Director be called upon by the DDA to represent the DDA at a conference, meeting, or other official occasion, the Director shall be reimbursed for expenses upon submittal of receipts. Receipts must be submitted within 5 days of the incurred expenses.

Section 6-5. Annual Audit.

The Treasurer may cause an annual audit of the books of the DDA, and present such audit to the Directors of the DDA. The City of Guyton shall include the DDA's finances with its copy of the audit that shall be filed with the State Auditor, if necessary, to comply with the Local Government Financial Management Standards Act (Georgia Laws, 1980, p. 1738). Audits may also be caused by a majority vote of the Directors.

ARTICLE 7: EFFECTIVE DATE

Section 7-1. Approval of by-laws

These by-laws as written and any amendments to said by-laws shall become effective upon approval by a majority vote of the Directors.

ARTICLE 8: AMENDMENTS

Section 8-1. Amendments.

The by-laws of the DDA shall be subject to alteration, amendment or repeal, and new by-laws not inconsistent with any laws of the State of Georgia creating this Authority may be made by affirmative vote of a majority of the Directors then holding office at any regular or special meeting of the Directors. Proposed amendments shall be submitted in writing to all Directors of the DDA ten (10) days prior to the meeting at which such amendment will be considered. If such written proposed amendment is submitted by email, it shall be deemed delivered when sent.

Resolved this __ day of _____, 2023 by the City of Guyton Downtown Development Authority.

, Chair

ATTEST:
